

SW11 SMALL SIZE MICRO SWITCHES



●Parameter

rating	01	1A 125V/250V AC 0.1A 125/250V AC 0.1A 36V DC
	02	2A 36V DC
	03	3A 125V/250V AC
	05	5(3)A 125/250V AC 1E4 5A 125/250V AC 5A 36V DC
	08	8(3)A 125/250V AC
	10	10.1(3)A 125/250V AC
life span	electrical	50,000 times 10-30 times/minute
	mechanical	300,000 times 60-120 times/minute
certificate	ENEC UL CUL CE CB ROHS	
initial contact resistance	50 mΩ Max	
insulation resistance	100MΩ Min	
electric tension	AC 1000V (50 ~ 60Hz)	
temperature	25T125	

●Contacting Picture

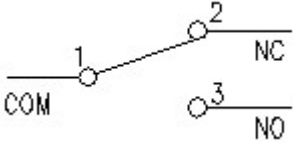
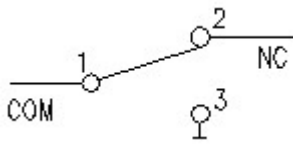
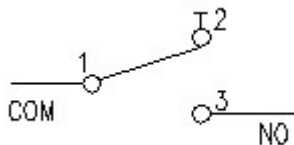
“Z” SPDT	“C” SPDT-NC	“P” SPDT-NO
		

●Size & Characteristic

SW11TA_012C

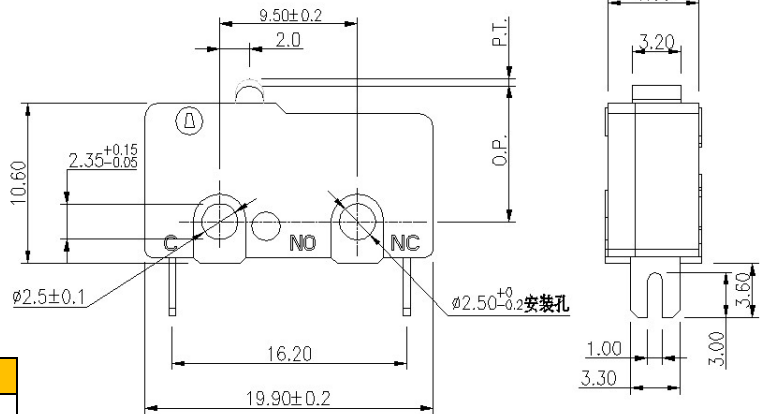

OF	RF	PT	DT	OP
200 gf Max	60 gf Min	0.6 mm Max	0.2 mm Max	8.4±0.5 mm
150 gf Max	45 gf Min			
100 gf Max	30 gf Min			

SW11TA_012P

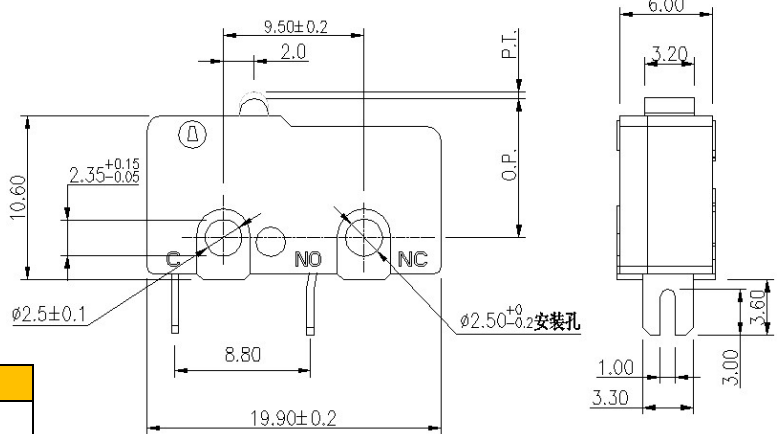

OF	RF	PT	DT	OP
200 gf Max	60 gf Min	0.6 mm Max	0.2 mm Max	8.4±0.5 mm
150 gf Max	45 gf Min			
100 gf Max	30 gf Min			

SW11TA_012Z

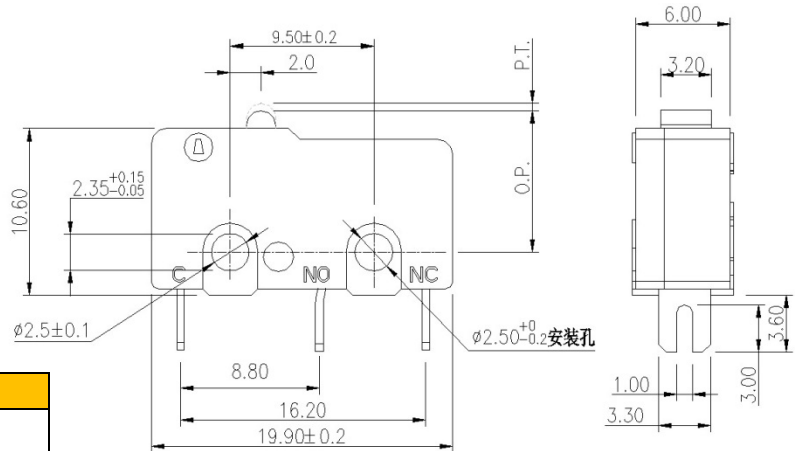

OF	RF	PT	DT	OP
200 gf Max	60 gf Min	0.6 mm Max	0.2 mm Max	8.4±0.5 mm
150gf Max	45 gf Min			
100 gf Max	30 gf Min			

●Operating Characteristic Diagrammatize

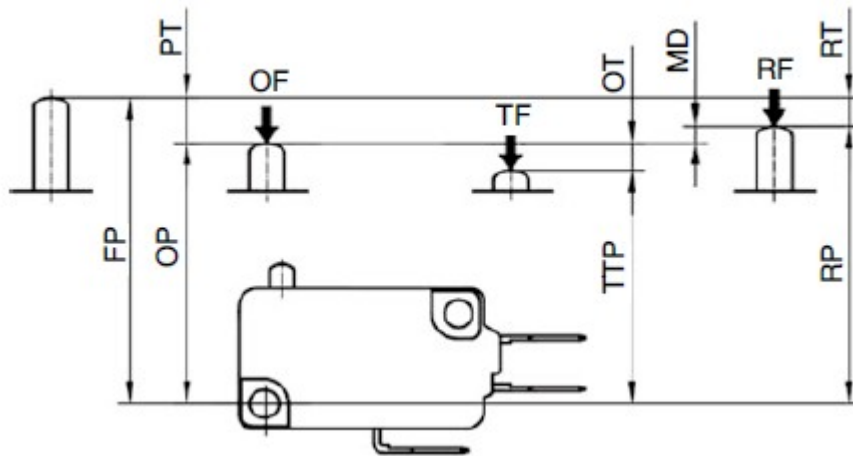

Name	Parameter	Explanation
PT	Pre Travel	Movement from Free Position to Over Position
OT	Over Travel	Movement from Over Position to Total Travel Position
DT	Movement Differential Travel	Movement from Over Position to Release Position
RT	Release Travel	Movement from Release Position to Free Position
OF	Operating Force	Max Operating Force from Free Position to Over Position
RF	Release Force	Minimal Operating Force from Over Position to Release Position
TTP	Total Travel Position	The drive member is located in the stop osition
OP	Over Position	Instant position in forward movement
RP	Release Position	Instant position in reverse movement
FP	Free Position	The position where the actuator lead the displacements when its out of force or the force is not enough to drive the actuator.